

cilindri tondi

round cylinders

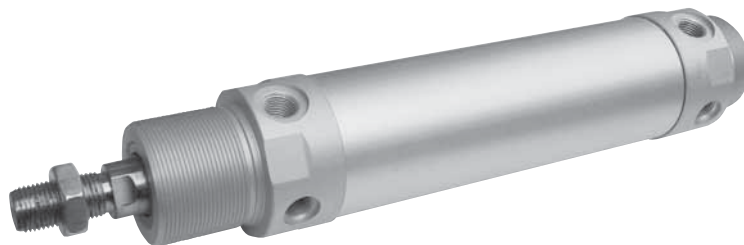

- Valida alternativa alle esecuzioni tradizionali
Up-to-date alternative to traditional versions
- Grande affidabilità e lunga durata
High reliability and long life time
- Versione magnetica standard
Standard magnetic version
- Esecuzioni speciali a richiesta
Special versions on request



Materiali

Camicia: alluminio

Stelo: C45 cromato o INOX

Testate: alluminio

Pistone: alluminio

Guarnizioni: NBR o VITON

Magnete: plastroferrite (non adatto per temperature oltre +60°C)

Guida pistone: teflon PTFE

Materials

Barrel: aluminium

Piston-rod: C45 (chromium plated) or stainless steel

End-cups: aluminium

Piston: aluminium

Sealings: NBR or VITON

Magnet: magnetic iron compound (not suitable for temperatures over +60°C)

Piston guide ring: teflon PTFE

Pressione di esercizio <i>Working pressure</i>	max 10 bar max 1 MPa
Temperatura di esercizio <i>Temperature range</i>	max +60°C
Alesaggi <i>Bores</i>	32; 40; 50 mm
Corse <i>Strokes</i>	25 ... 500 mm
Fluido <i>Fluid</i>	Aria filtrata 50µ con o senza lubrificazione <i>50µ filtered, lubricated or non lubricated air</i>

chiave di codifica

key to codes

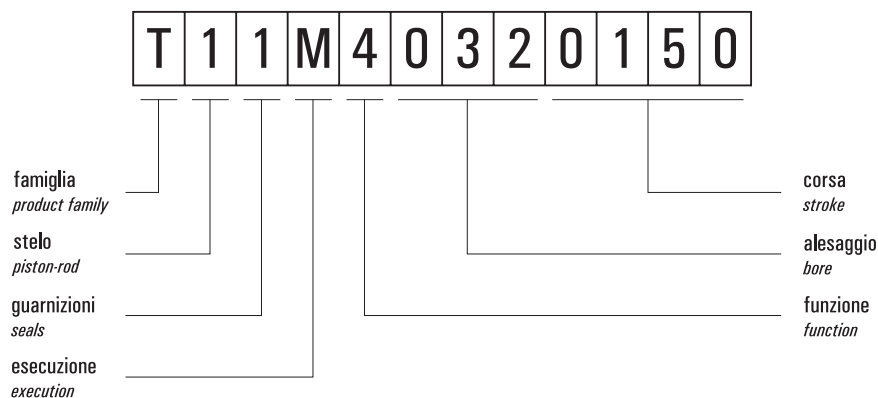

Famiglia *[product family]*

T cilindri tondi *[round cylinders]*

Stelo *[piston-rod]*

- 1** C45 cromato *[C45 chromium plated]*
- 2** INOX *[stainless steel]*

Guarnizioni *[seals]*

- 1** NBR
- 2** tutte le guarnizioni in VITON *[all seals in VITON]*
- 3** guarnizioni dello stelo in VITON *[rod seals in VITON]*

Esecuzione *[execution]*

M magnetico *[magnetic]*

Funzione *[function]*

- 2** doppio effetto non ammortizzato
[double acting without pneumatic cushioning]
- 3** doppio effetto ammortizzato
[double acting with pneumatic cushioning]
- 4** doppio effetto non ammortizzato stelo passante
[double acting without pneumatic cushioning, with passing-through rod]
- 5** doppio effetto ammortizzato stelo passante
[double acting with pneumatic cushioning, with passing-through rod]

versioni disponibili

available versions

doppio effetto <i>double acting</i> magnetico <i>magnetic</i> non ammortizzato <i>without pneumatic cushioning</i>	alesaggio		32	40	50	OPZIONI <i>options</i> Lo standard è evidenziato in grigio <i>The standard is marked with grey background</i>
	corsa	bore				
	25	stroke	X	X	X	materiale stelo [piston-rod material] C45 cromato <i>C45 chromium plated</i> INOX <i>stainless steel</i> materiale guarnizioni [seals material] NBR tutte in VITON <i>all seals in VITON</i> guarnizioni stelo in VITON <i>rod seals in VITON</i>
	50		X	X	X	
	75		X	X	X	
	80		X	X	X	
	100		X	X	X	
	125		X	X	X	
	150		X	X	X	
	160		X	X	X	
	200		X	X	X	
	250		X	X	X	
	300		X	X	X	
	320		X	X	X	
	400		X	X	X	
	500		X	X	X	
	doppio effetto <i>double acting</i> magnetico <i>magnetic</i> non ammortizzato <i>without pneumatic cushioning</i> stelo passante <i>passing-through rod</i>	alesaggio		32	40	
corsa		bore				
	25	stroke	X	X	X	materiale stelo [piston-rod material] C45 cromato <i>C45 chromium plated</i> INOX <i>stainless steel</i> materiale guarnizioni [seals material] NBR tutte in VITON <i>all seals in VITON</i> guarnizioni stelo in VITON <i>rod seals in VITON</i>
	50		X	X	X	
	75		X	X	X	
	80		X	X	X	
	100		X	X	X	
	125		X	X	X	
	150		X	X	X	
	160		X	X	X	
	200		X	X	X	
	250		X	X	X	
	300		X	X	X	
	320		X	X	X	
	400		X	X	X	
	500		X	X	X	

versioni disponibili

available versions

doppio effetto <i>double acting</i> magnetico <i>magnetic</i> ammortizzato <i>with pneumatic cushioning</i>	alesaggio		32	40	50	OPZIONI <i>options</i> Lo standard è evidenziato in grigio <i>The standard is marked with grey background</i>					
	corsa	bore									
	25		X	X	X	materiale stelo [piston-rod material] <table border="1"> <tr> <td>C45 cromato <i>C45 chromium plated</i></td> <td>INOX <i>stainless steel</i></td> </tr> </table> materiale guarnizioni [seals material] <table border="1"> <tr> <td>NBR</td> <td>tutte in VITON <i>all seals in VITON</i></td> <td>guarnizioni stelo in VITON <i>rod seals in VITON</i></td> </tr> </table>	C45 cromato <i>C45 chromium plated</i>	INOX <i>stainless steel</i>	NBR	tutte in VITON <i>all seals in VITON</i>	guarnizioni stelo in VITON <i>rod seals in VITON</i>
	C45 cromato <i>C45 chromium plated</i>	INOX <i>stainless steel</i>									
	NBR	tutte in VITON <i>all seals in VITON</i>	guarnizioni stelo in VITON <i>rod seals in VITON</i>								
	50		X	X	X						
	75		X	X	X						
	80		X	X	X						
	100		X	X	X						
	125		X	X	X						
	150		X	X	X						
	160		X	X	X						
	200		X	X	X						
	250		X	X	X						
	300		X	X	X						
	320		X	X	X						
	400		X	X	X						
500		X	X	X							
doppio effetto <i>double acting</i> magnetico <i>magnetic</i> ammortizzato <i>with pneumatic cushioning</i> stelo passante <i>passing-through rod</i>	alesaggio		32	40	50	OPZIONI <i>options</i> Lo standard è evidenziato in grigio <i>The standard is marked with grey background</i>					
	corsa	bore									
	25		X	X	X	materiale stelo [piston-rod material] <table border="1"> <tr> <td>C45 cromato <i>C45 chromium plated</i></td> <td>INOX <i>stainless steel</i></td> </tr> </table> materiale guarnizioni [seals material] <table border="1"> <tr> <td>NBR</td> <td>tutte in VITON <i>all seals in VITON</i></td> <td>guarnizioni stelo in VITON <i>rod seals in VITON</i></td> </tr> </table>	C45 cromato <i>C45 chromium plated</i>	INOX <i>stainless steel</i>	NBR	tutte in VITON <i>all seals in VITON</i>	guarnizioni stelo in VITON <i>rod seals in VITON</i>
	C45 cromato <i>C45 chromium plated</i>	INOX <i>stainless steel</i>									
	NBR	tutte in VITON <i>all seals in VITON</i>	guarnizioni stelo in VITON <i>rod seals in VITON</i>								
	50		X	X	X						
	75		X	X	X						
	80		X	X	X						
	100		X	X	X						
	125		X	X	X						
	150		X	X	X						
	160		X	X	X						
	200		X	X	X						
	250		X	X	X						
	300		X	X	X						
	320		X	X	X						
	400		X	X	X						
500		X	X	X							

6

cilindri tondi

round cylinders

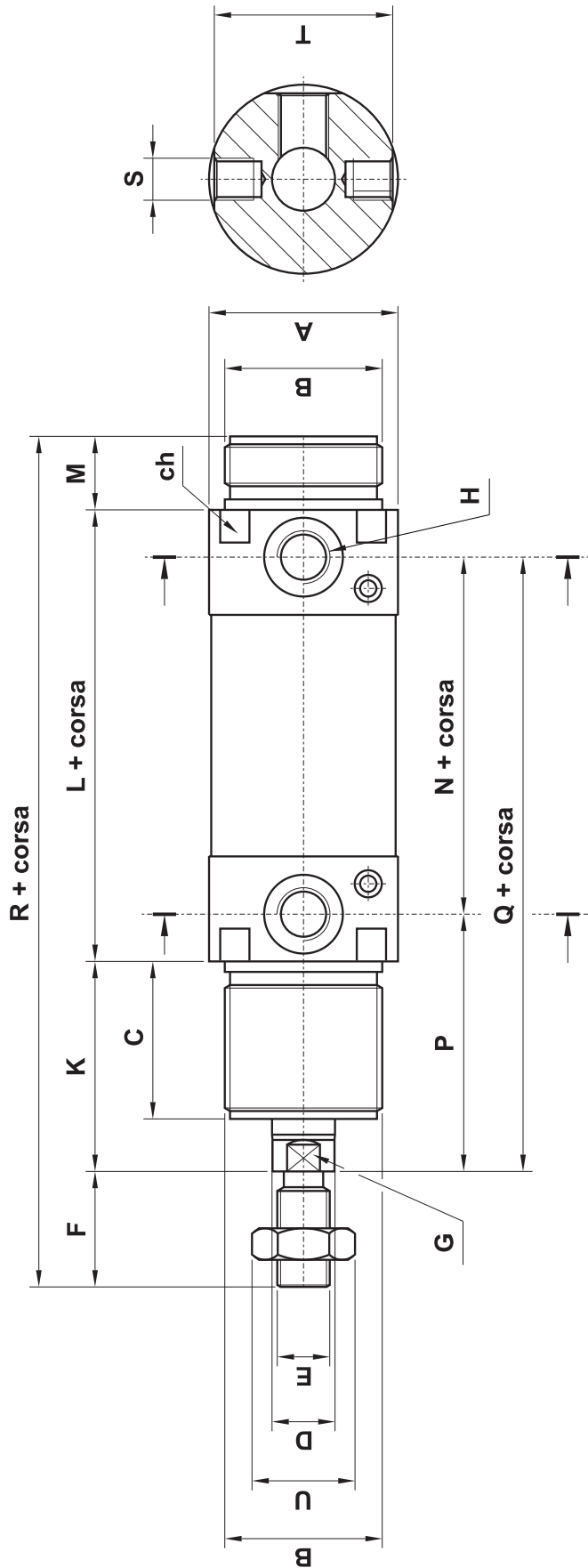

\varnothing	A	B	C	D	E	F	G	H	ch	K	L	M	N	P	Q	R	S	T	U
32	$\varnothing 38$	M30x1.5	30	$\varnothing 12$	M10x1.25	20	CH 10	G1/8"	36	38	96	14	78	47	125	168	M8x1	35	CH 17
40	$\varnothing 46$	M38x1.5	35	$\varnothing 16$	M12x1.25	24	CH 13	G1/4"	45	45	113	16	89	57	146	198	M10x1	42	CH 19
50	$\varnothing 57$	M45x1.5	38	$\varnothing 20$	M16x1.5	32	CH 17	G1/4"	55	50	120	18	96	62	158	220	M12x1.5	53	CH 24

cilindri tondi

round cylinders



VERSIONE STELO PASSANTE

Version with passing-through rod

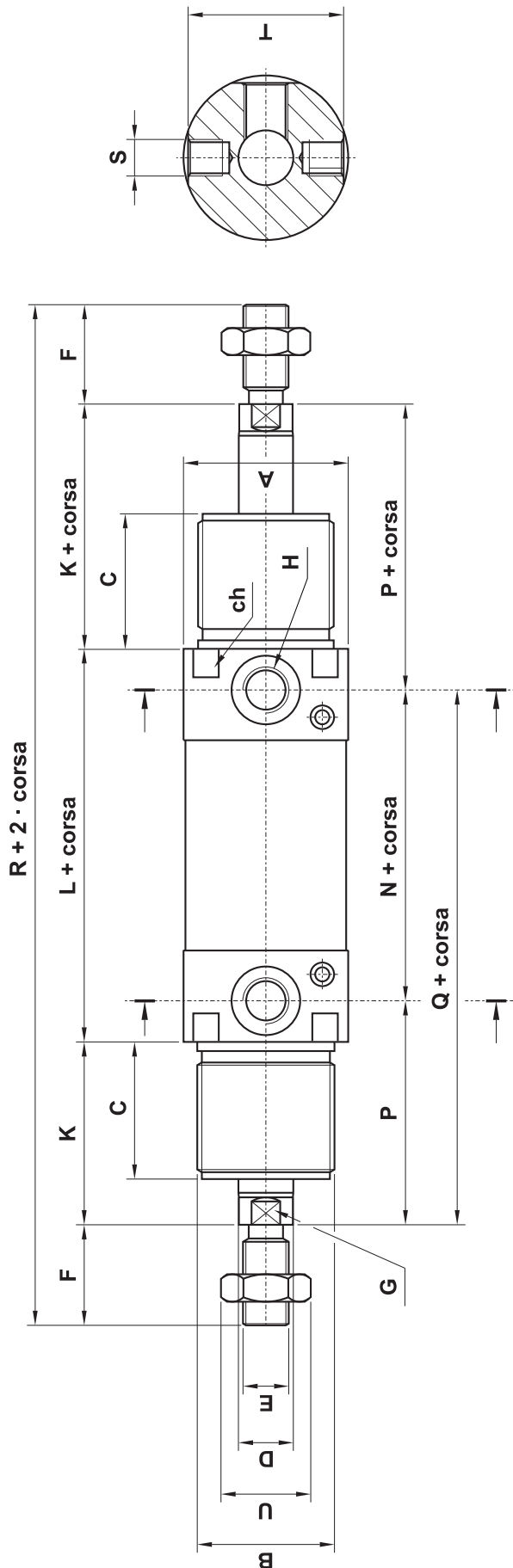

Ø	A	B	C	D	E	F	G	H	ch	K	L	N	P	Q	R	S	T	U
32	ø38	M30x1.5	30	ø12	M10x1.25	20	CH 10	G1/8"	36	38	96	78	47	125	212	M8x1	35	CH 17
40	ø46	M38x1.5	35	ø16	M12x1.25	24	CH 13	G1/4"	45	45	113	89	57	146	251	M10x1	42	CH 19
50	ø57	M45x1.5	38	ø20	M16x1.5	32	CH 17	G1/4"	55	50	120	96	62	158	284	M12x1.5	53	CH 24



kit guarnizioni di ricambio

seals kit

NBR - MAGNETICO

non ammortizzato			ammortizzato		
per alesaggio for bore	sigla part number	codice code	per alesaggio for bore	sigla part number	codice code
32	SGT032	26.192.2N	32	SGT032A	26.430.2
40	SGT040	26.193.2N	40	SGT040A	26.431.2
50	SGT050	26.194.2N	50	SGT050A	26.432.2

VITON - MAGNETICO

non ammortizzato			ammortizzato		
per alesaggio for bore	sigla part number	codice code	per alesaggio for bore	sigla part number	codice code
32	SGT032V	26.360.2N	32	SGT032AV	26.433.2
40	SGT040V	26.361.2N	40	SGT040AV	26.434.2
50	SGT050V	26.362.2N	50	SGT050AV	26.435.2

fissaggi per cilindri tondi

fixing elements for round cylinders



GHIERA

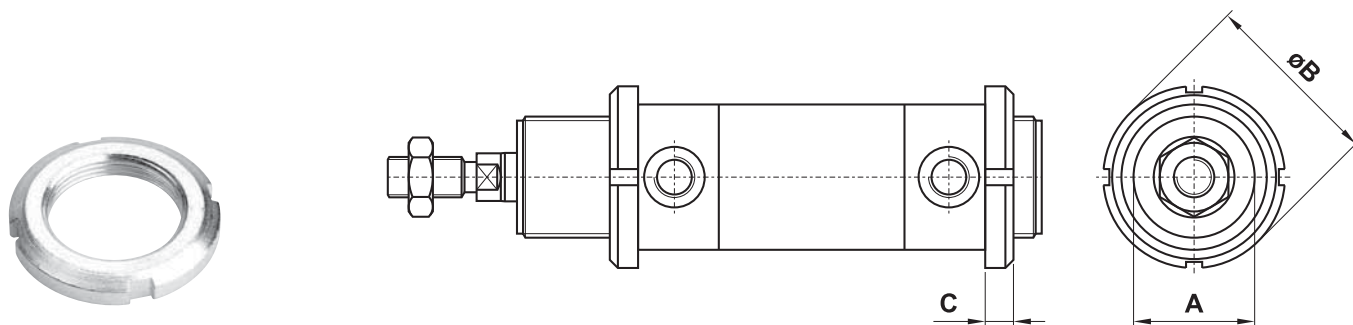

sigla part number	per alesaggio for bore	A	B	C
GPT032	32	M30x1.5	45	7
GPT040	40	M38x1.5	50	8
GPT050	50	M45x1.5	58	9

CONTROCERNIERA CON PERNO

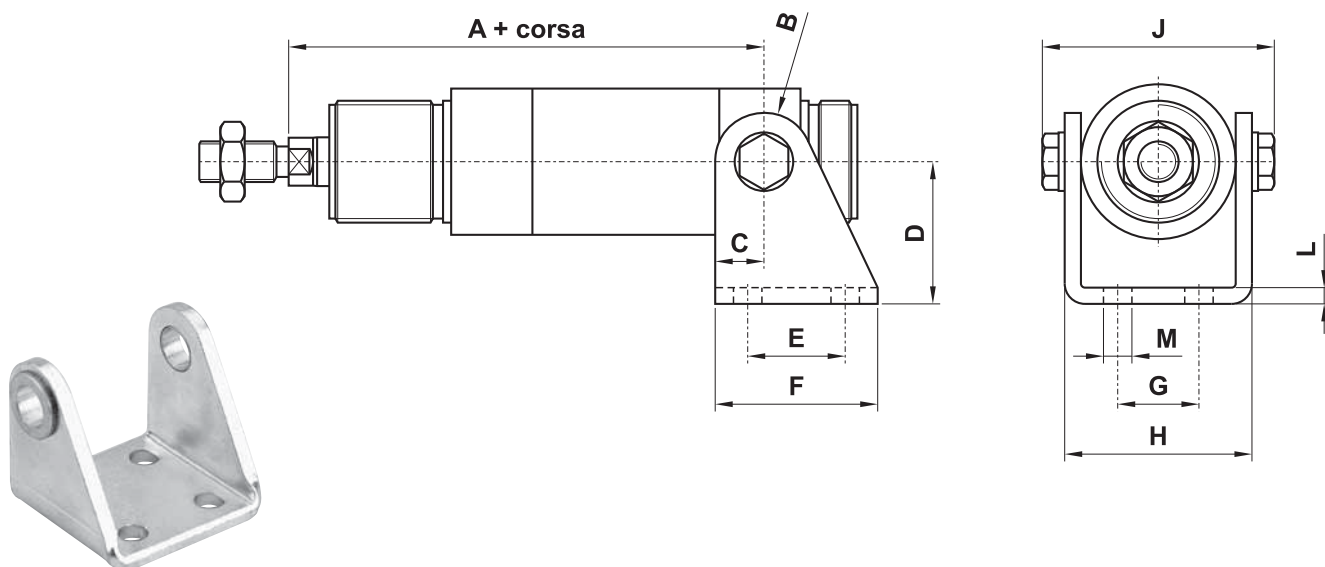

sigla part number	per alesaggio for bore	A	B	C	D	E	F	G	H	J	L	M
CCR032	32	125	12	12	35	24	40	20	46	58	4	ø7
CCR040	40	146	13	13	40	30	50	28	56	70	5	ø9
CCR050	50	158	14	14	45	34	54	36	69	86	6	ø9

fissaggi per cilindri tondi

fixing elements for round cylinders



PIEDINO

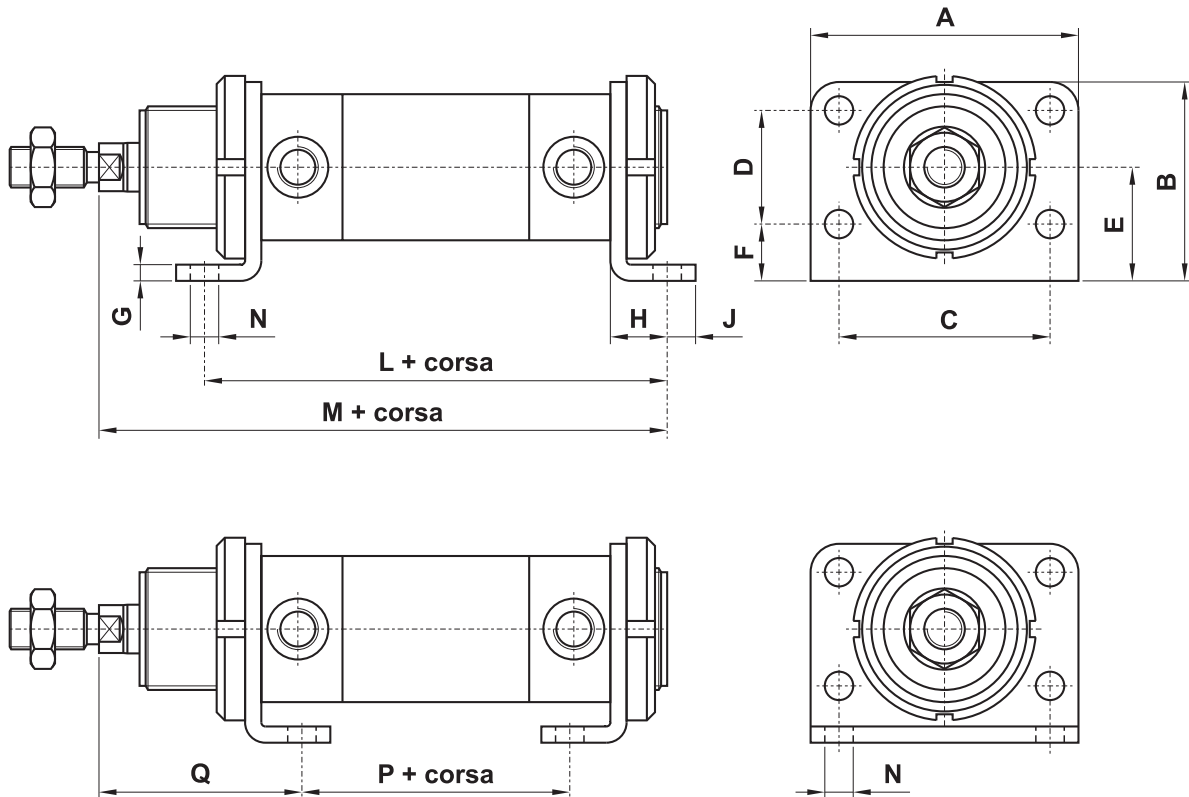

sigla* part number*	per alesaggio for bore	A	B	C	D	E	F	G	H	J	L	M	N	P	Q
FPT032	32	66	49	52	28	28	14	4	14	7	124	148	ø7	76	48
FPT040	40	80	58	60	30	33	18	5	20	10	153	178	ø9	83	60
FPT050	50	90	70	70	40	40	20	6	20	10	160	190	ø9	92	64

* La sigla si riferisce a un solo piedino e non alla coppia

* The part number is referred to only one element and not to the couple